

SENSOR LIQUID SOAP DISPENSER LN102E-1



LN
LINE

120 x 344 x 138 mm

850 ml plug-in tank

- Sensor liquid soap dispenser in robust, germ-reducing and easy-care stainless steel (AISI 316L).
- Modular all-stainless steel housing; consisting of a mounting back panel, body and a 2 mm thick, straight front panel, visible surfaces satin finished and brushed. Further available surfaces: see below.
- With EWAR® eModule touch-free operated and non-drip soap pump with 850 ml plug-in tank.
- Designed for standard liquid soaps or hand lotions.
- Inspection slot to indicate fill level.
- Accessible for refilling through lockable, foldable or, alternatively removable front panel with fall protection.
- Invisible housing lock on the top, can be unlocked using a magnetic key.
- eModule battery-powered with two 1.5 V Baby/LR14 batteries. Power supply available as an option.
- Wear parts can be replaced as modules.
- Mounting: Wall mounting of the back panel with 2 screws and an optional anti-theft hole, then screwing the body to the back panel and hanging the front panel.
- Delivery includes fixing material and batteries.
- Weight, including single package: 3.6 kg

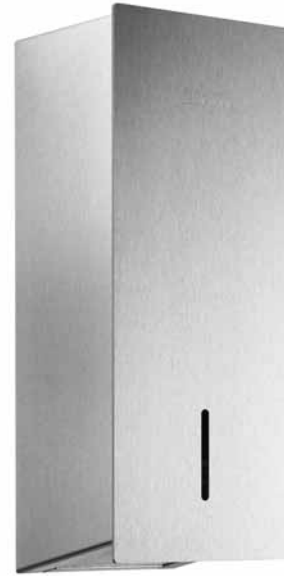

Suggested text for specifications:

Sensor liquid soap dispenser in stainless steel (AISI 316L) for surface mounting. Modular all-stainless steel housing; consisting of a mounting back panel, body and a 2 mm thick, straight front panel, visible surfaces satin finished and brushed. With touch-free operated and non-drip soap pump with 850 ml plug-in tank. Designed for standard liquid soaps or hand lotions. Inspection slot to indicate fill level. Accessible for refilling through lockable, hinged housing. Accessible for refilling through lockable, foldable or, alternatively removable front panel with fall protection. Invisible housing lock on the top, can be unlocked using a magnetic key. Delivery includes fixing material and batteries.

Dimensions: 120 x 344 x 138 mm

Article No. LN102e-1

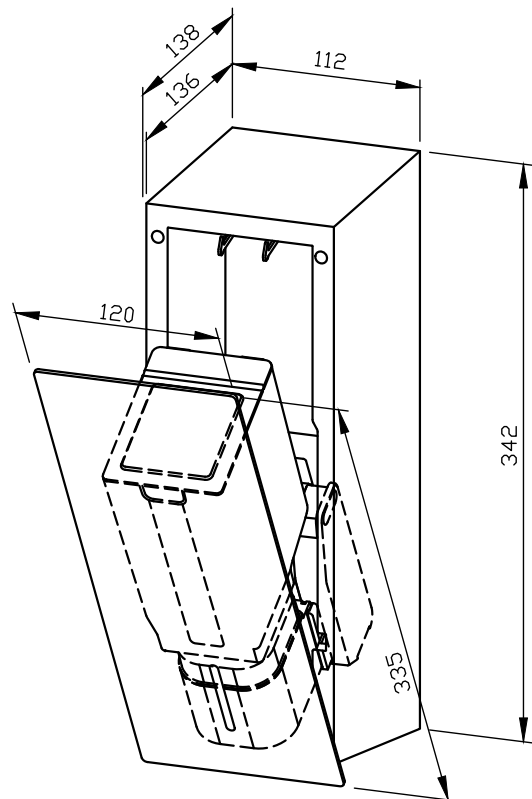

Options	ID No.
Power supply for eModule	923 060
Available surfaces	ID No.
satin finished (standard)	827 114
highly polished	831 114
(coloured) plastic powder-coating	828 114

Ernst Wagner GmbH & Co. KG

Ernst-Abbe-Straße 21 · D-72770 Reutlingen · Tel.: +49712151539-0 · Fax: -20
info@wagner-ewar.de · www.wagner-ewar.de

WAGNER
EWAR